

# A Clutter Canceller for Continuous Wave GPR

Gilberto Grazzini, Massimiliano Pieraccini,  
Filippo Parrini, Carlo Atzeni  
Dept. Electronics and Telecommunications,  
University of Florence

Via Santa Marta 3, 50139, ITALY  
gilberto.grazzini@unifi.it , massimiliano.pieraccini@unifi.it

**Abstract**— In this work an innovative clutter canceller for Continuous Wave GPR (Ground Penetrating Radar) has been designed and implemented. An IQ modulator has been used to build up the central part of the device. The IQ modulator replaces more expensive components like digital controlled phase shifters and attenuators. This device also have wider dynamics with respect to linear vectorial modulator. To prove the feasibility of the system, the effect of signal feedthrough for IQ modulators is studied. Tests and measurements of the complete device are exposed.

**Index Terms**—Continuous Wave, Clutter Canceller, GPR, IQ modulator,

## I. INTRODUCTION

Generally speaking, the clutter is backreflected signal due to the surrounding environment and not to the proper targets [1]. The clutter can be a static signal due to targets like mountains or buildings, or can be caused by non static effects like rain, sea waves. Furthermore, clutter definition is related to the purpose of the radar: for example rain reflection can be clutter for a tracking radar while can be the target signal for a meteorological radar.

For penetrating radar, clutter is due mainly by the direct coupling between transmitting and receiving elements of the system or, for non contact system, the first reflection due to the air-surface interface. For penetrating radar aimed to detect vital signal of buried or hidden people, clutter is everything but the signal modulated by chest or heart movement[2].

Pulse radar can exploit the Range Gate Pulse approach that is able to cut the direct coupling and the first reflection, but it is not effective for distributed clutter source.

Range Gate Pulse is not applicable to Continuous Wave (CW) radar, therefore direct coupling and the first reflection are critical problems for this kind of radar.

In this paper, the authors propose a clutter canceller for coherent radar able to cut out all static clutter, so particularly suitable for detecting vital signals of buried people.

## II. BACKGROUND

Generally speaking, clutter suppression for radar can be carried out by hardware and software methods. When the problem due to the clutter is a deterioration of the resulting radar image the software method is preferred, just because the duty of the clutter canceller is a clearing of the unwanted data, which in many cases can be differentiate from the target data by the property of time variation. The hardware method is used when the clutter problem can affect the detection of the target,

that is when the clutter radiofrequency power can reduce the sensitivity or even saturate the receiving sub-system components. The clutter canceller developed in this work has to be implemented in a CW radar which is used to detect the doppler shift of the electromagnetic wave reflected by a target. In this case the clutter is the whole static reflection due to the surrounding objects and to the direct coupling of the antennas. If this radar is used in Ground Penetrating System for detecting alive buried people, the clutter is then due mainly to the reflection of the air-ground interface which reflects most of the transmitted power. If this power is able to saturate the first element of the receiving sub-system is obvious that the detection is not more possible because a saturated device cannot follow the tiny variation due to the movement of chest and heart during breath and cardiac pulse. The hardware clutter canceller developed in this work eliminates the clutter power before it reaches the elements which can be saturated. The physical principle used to discriminate the target data from the received power is simple, because a CW radar which doesn't use distance measuring methods like Stepped Frequency or Frequency Modulation, can only detect the instantaneous variation of the position of the target measuring the doppler shift of the reflected electromagnetic wave. The whole static reflection, that is the reflection which doesn't vary its phase, amplitude or frequency during the measure, is clutter and then has to be eliminated. The phasorial representation of an example of received signal is shown in Fig. 1 :

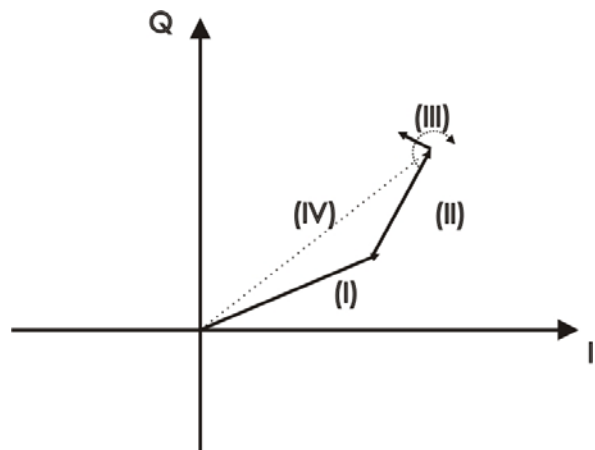

Fig. 1 – Phasorial representation of received signal

The vector (I) and (II) are representative of two generic clutter signals, so they can be summed together obtaining the dashed vector which is the total clutter. The vector (III) is the

signal due to the target which has a phase modulation due to the movement of the interface which has produced it. An analytic representation of the received signals is also shown in (1):

$$A_1 \cos(\omega t + \varphi_1) + A_2 \cos(\omega t + \varphi_2) + A_3 \cos(\omega t + \Delta\varphi(t)) \quad (1)$$

Where  $A_i$  ( $i=1,2,3$ ) are the amplitude of the signals,  $\omega$  is the pulsation,  $\varphi_i$  ( $i=1,2$ ) are the static phases of the clutter signals and  $\Delta\varphi(t)$  is the variable phase of the wanted signal. The first two component are the clutter signal, the third component represents the target signal with the phase referred to the displacement of the object. The next equation shows the received signal in which clutter and target signal are distinguished:

$$A_c \cos(\omega t + \varphi_c) + A_3 \cos(\omega t + \Delta\varphi(t)) \quad (2)$$

The first component represents the clutter, while the second one is the phase varying signal. To delete the clutter signal the canceller has to generate a signal whose phasor has same amplitude and an opposite phase compared with the clutter signal. This signal has to be summed with the received power with an appropriate device, and the result is shown in the next expression:

$$\begin{aligned} A_c \cos(\omega t + \varphi_c) + A_3 \cos(\omega t + \Delta\varphi(t)) - \\ A_c \cos(\omega t + \varphi_c) = A_3 \cos(\omega t + \Delta\varphi(t)) \end{aligned} \quad (3)$$

The target signal is not affected by the cancellation, even because it has got a phase modulation which has widened his spectrum, thus the single signal produced by the clutter canceller cannot delete this information.

Fig. 2 shows the resulting signal resulting from the clutter cancellation:

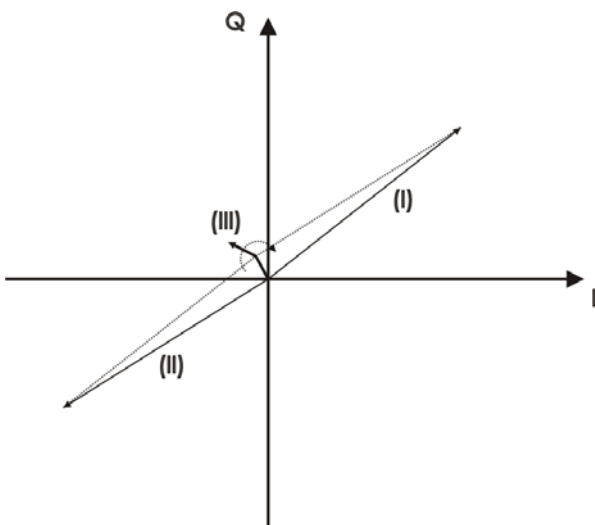

Fig. 2 – Received signal after clutter suppression

Dashed phasor number (I) indicates the total clutter signal before the suppression, signal (II) is the one used to accomplish

clutter cancellation, while (III) is the signal after the cancellation. Due to finite precision of the system, a complete clutter cancellation is not possible, so a small clutter signal has been represented together with phase varying signal. As it can be seen, signal (III) needs a lower dynamics of receiver to be correctly demodulated without reaching saturation.

### III. ARCHITECTURE

In Fig. 3 it is shown a sketch of a typical coherent CW radar:

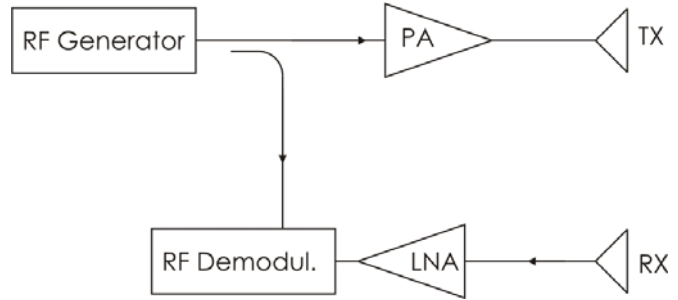

Fig. 3 - Coherent CW RADAR

The image shows the LNA *Low Noise Amplifier* as first element of a receiving sub-system, so the clutter suppression must be achieved before this stage. Fig. 4 shows the simplest way to generate the signal, that is to withdraw another part of the transmitting signal, bring the needed modify and then combine the interested signals. The duty of the clutter canceller is to bring phase shifting and attenuation or amplification at the RF withdrawal to generate the wanted signal. The basic configuration includes digital controlled phase shifter and attenuator. This configuration has the advantage in the simplicity, on the other hand the problem consists in the digital controls for the attenuator and the phase shifter. The precision for these devices is limited, and unlikely exceeds 5-6 bit, furthermore these devices are very expensive and hard to find.

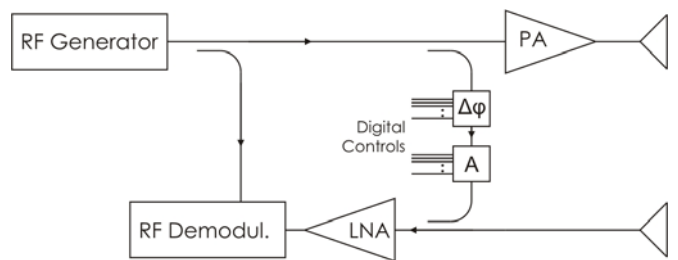

Fig. 4 – Phase-Amplitude configuration for clutter canceller

In Fig. 5 the configuration with the implementation of an IQ modulator is shown. This configuration allows an analog control of the IQ modulator, so the precision of the system can be chosen with the Digital to Analog Converter (DAC).

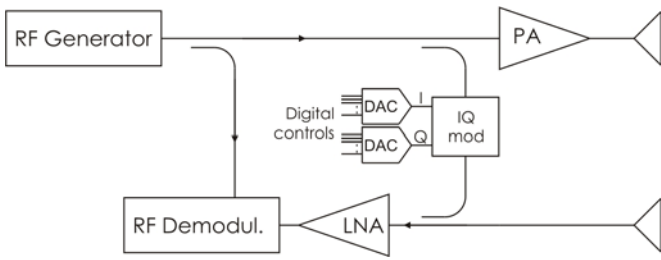

Fig. 5 – IQ configuration for clutter canceller

The IQ modulator is capable of generating a wide number of modulations, but in this application it is used to obtain a phase shifter and an attenuator in a sole device. The modulator has one RF input, 2 distinct low frequency inputs and an RF output.

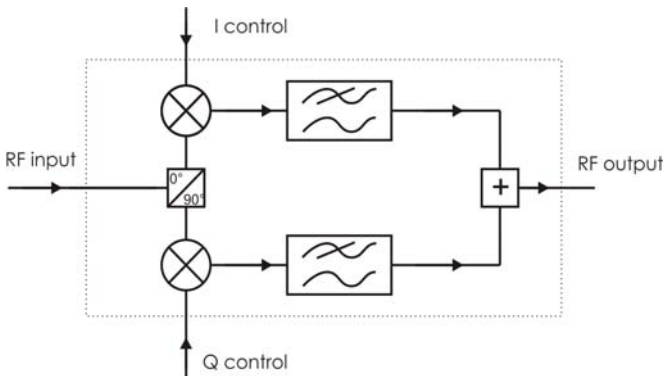

Fig. 6 – IQ modulator

Fig. 6 shows the internal configuration of a generic IQ modulator. The RF input is splitted into two quadrature vector, and then multiplied by two constant signals, which vary the amplitudes and the signs of the two separate quadrature vectors. This two signals are then summed together in order two obtain the output signal. This device allows separate controls for I and Q simply controlling two constant voltages. The main difference between this configuration and the previous one is digital interface separated from analog interface, so now the digital precision can be chosen separately from radiofrequency specifications. Previous works [3] uses IQ modulator to obtain phase shifting, while amplitude control was due to a separated attenuator, in this work the IQ modulator functions as phase shifter and attenuator together simplifying hardware configuration. Unlike vectorial modulator, also used as clutter canceller [4], IQ modulator has a wider dynamics due to the presence of mixers instead of variable attenuator. On the other hand the presence of non-linear devices like mixer brings some undesired effect. In particular there will be carrier feedthrough, that is a fraction of the input power which goes through the mixing stage without being multiplied with the DC input. This is due to an non-ideal input-output isolation. The carrier feedthrough has an amplitude which depends on many factors, but for commercial

devices this characteristic is around  $-30\div-40\text{dB}$  under the RF input signal. Given that the input RF signal has to drive the local oscillator ports of two mixers, the power level has to be constant, so the feedthrough power become very relevant when the output of the IQ modulator is low with respect to RF input power. Tests are been carried out to show feedthrough behavior against any variation of IQ modulator output. Fig. 7 show the measurements setup used to characterize feedthrough behavior:

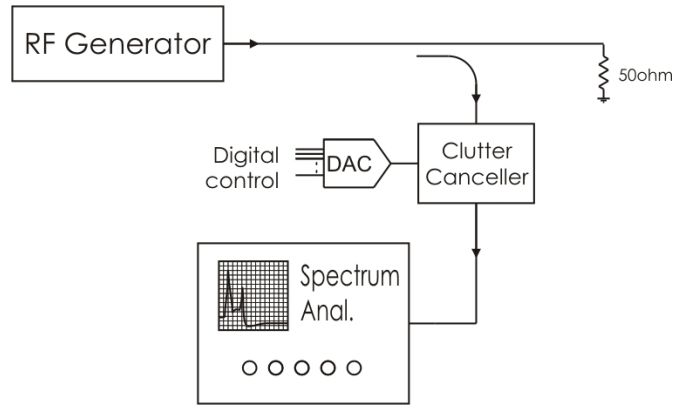

Fig. 7 – First measurement setup

The purpose of this test was to show that device feedthrough is constant against every change of I and Q voltages, so the feedthrough is static and can be considered clutter and then eliminated. To obtain this measure the clutter canceller has been driven with an amplitude constant – phase variable signal, that in the ideal case should be a circle in the IQ plane.

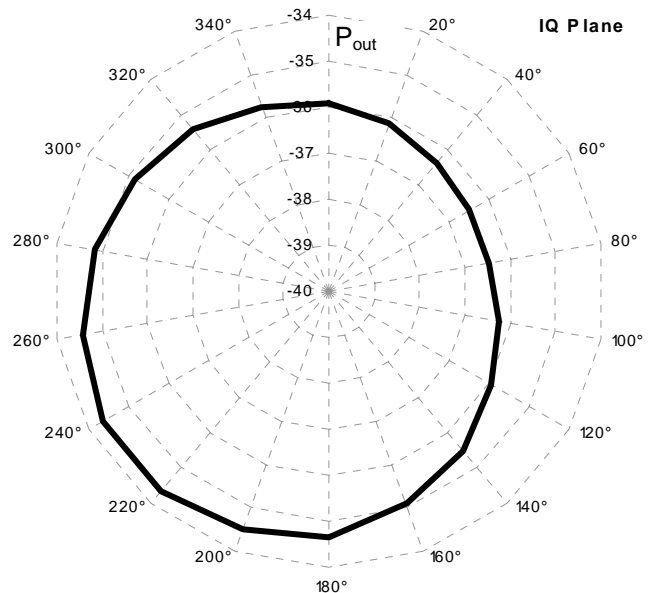

Fig. 8 – Output of IQ modulator in IQ plane

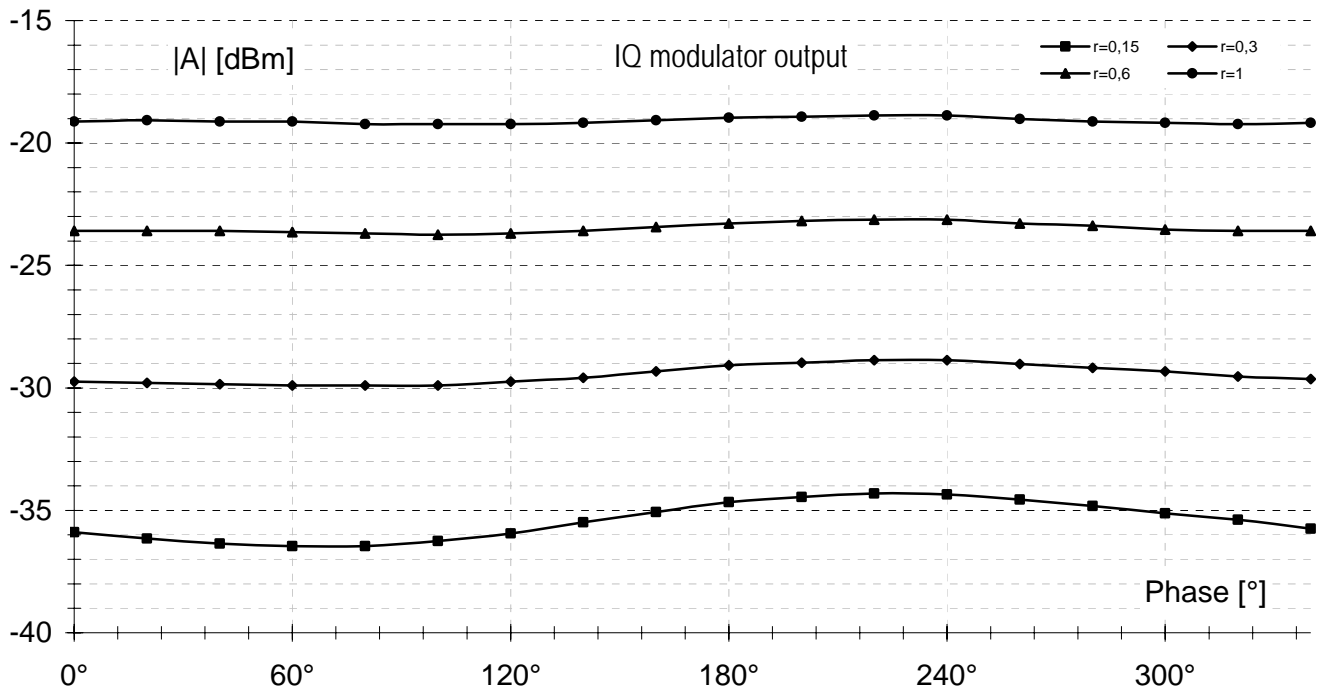

Fig. 9 - Amplitude varying IQ output

shows the output of the IQ modulator driven with amplitude constant IQ signal. In the ideal case the circle should be centered in zero, but the feedthrough shifts the circle so that it is not centered. This happens because feedthrough signal is constant against phase variations of output signal.

In the graph in Fig. 9 four different measurements are shown. These measures are obtained as the previous one driving the IQ modulator to have a constant amplitude output, but now four different amplitudes are represented with  $r$  as an arbitrary attenuation factor.

As it can be seen when the output power is low ( $r=0,15$   $r=0,3$ ) the graph shows an ondulatory pattern which is due to the phase-varying output signal summed with the static feedthrough. This pattern diminishes when the power raises because the feedthrough power remains constant and becomes negligible with respect to output power.

These measurements show that feedthrough is a static signal, with respect to any variation of output signal, so feedthrough can be treated as clutter and appropriately cancelled.

#### IV. TEST MEASUREMENTS

The experimental setup which has been installed to test the complete is shown in

Fig. 10. It uses an RF cable to simulate the clutter signal, thus changing the length of the cable and the value of fixed attenuators it is able to test the device with different phase-amplitude clutter.

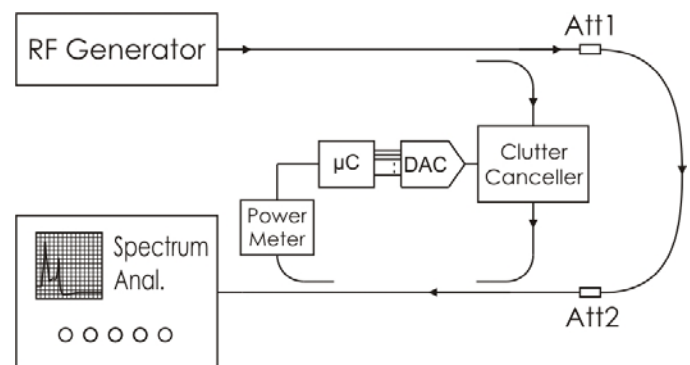

Fig. 10 - Second measurement setup

Digital control of the system is performed by a microcontroller ( $\mu\text{C}$ ) which input is an analog voltage proportional to the input power obtained by means of a power meter. The program routine of the  $\mu\text{C}$  varies the clutter canceller output, and then it drives the IQ modulator to obtain the minimum power on the receiver line. On Fig. 11 final measurements are reported. There are four different measure obtained with four cables with different length, thus to have four different clutter phase. Furthermore the values of two attenuator, Att1 and Att2, have been varied to have different clutter amplitude.

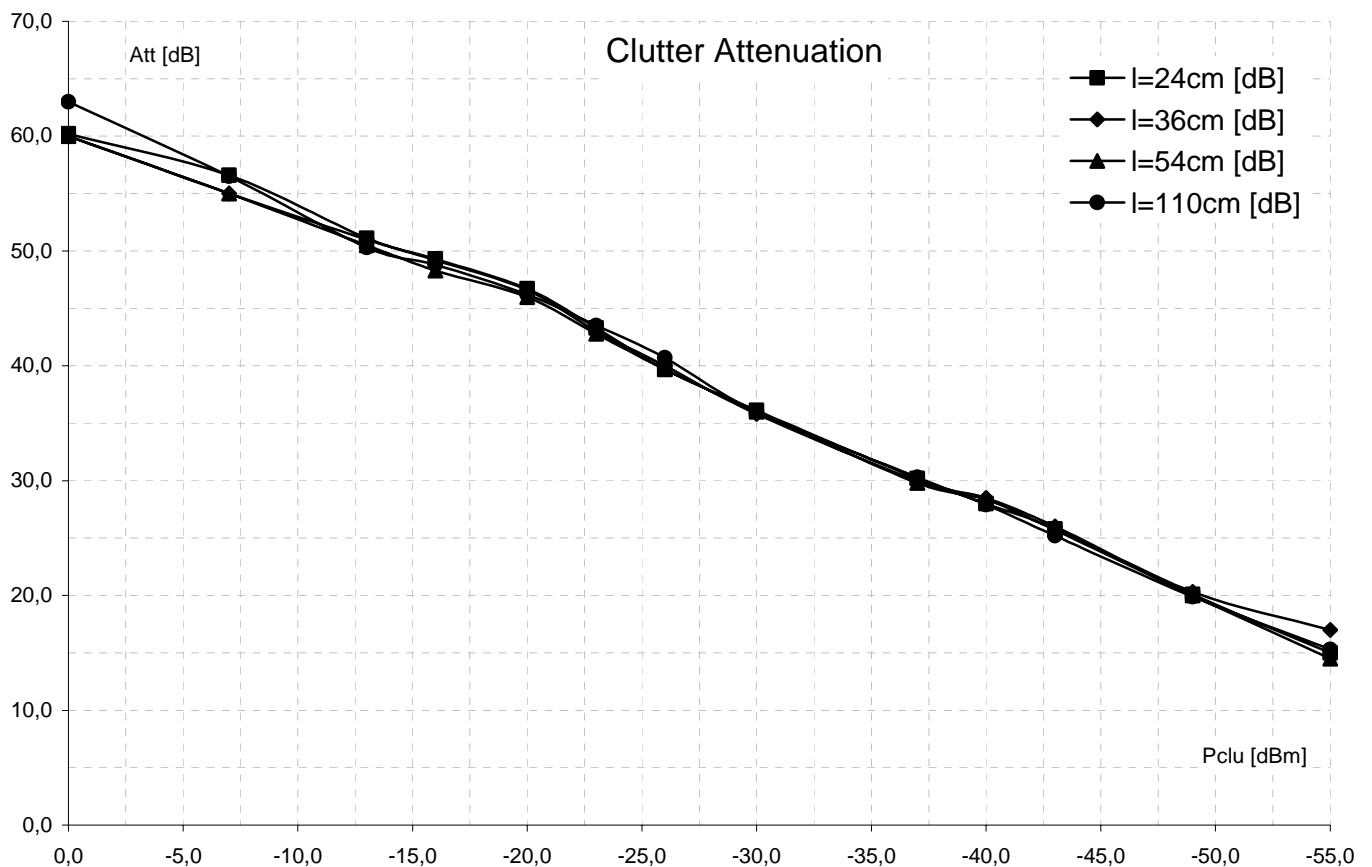

Fig. 11 – Clutter attenuation

## V. CONCLUSION

Fig. 11 shows clutter attenuation against received clutter power. The attenuation factor of the clutter canceller showed in this paper reach the value of 60dB when the clutter power is high ( $\approx 0$ dBm), otherwise there is lower attenuation when the clutter power diminishes. This is due to the finite precision of the DAC which drives the IQ modulator. This imperfection is much more visible when the clutter power is low, because the relative error increases when IQ output power decreases.

To obtain maximum performances is necessary a calibration of the system, to have the IQ modulator to work in high precision zone.

## VI. ACKNOWLEDGMENTS

The activity described in this work has been partially supported by ORFEUS (Optimised Radar to Find Every Utility in the Street) Project under the Sixth Framework Programme

## REFERENCES

- [1] F. E.Nathanson, Radar Design Principles. New York: McGraw-Hill, 1969.
- [2] K. Hatakeyama, Y. Sakata, T. Hashimoto, K. Yamauchi, "Detection of buried human body by electromagnetic wave reflection" *International Symposium on Electromagnetic Compatibility*, 1999. pp.805, May 1999
- [3] M. H. Kabutz, A.Langman, M.R. Inggis, "Hardware Cancellation of the Direct Coupling in a stepped CW Ground Penetrating Radar" *Geoscience and Remote Sensing Symposium*, 1994. vol. 4, pp. 2505-2507, Aug. 1994
- [4] P.D.L. Beasley, A.G. Stove, B.J. Reits, B, As, "Solving the problems of a single antenna frequency modulated CWradar" *Radar Conference*, 1990, pp. 391-395, May 1990